

South Carolina Large Non-Commercial and Recreational Vehicles Driver's Manual



South Carolina

**Large Non-Commercial &
Recreational Vehicles**

Driver's Manual

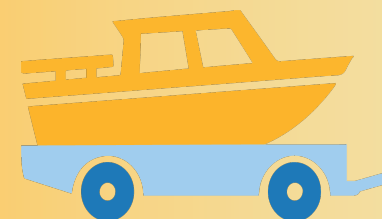

dmv.sc.gov

SC Department of Motor Vehicles

SC Department of Motor Vehicles
PO BOX 1498
Blythewood, SC 29016
803-896-5000
dmv.sc.gov

Revised 02/2019

TABLE OF CONTENTS

Purpose of this Manual.....	1
License Classes and Requirements	3
Equipment and Operating Controls	5
Loading and Overloading Information.....	9
Driving Techniques	13
Towing Safely	37
Requirements to Get a Non-Commercial Class E or F License	47
Skills Test	49
Vehicle Inspection.....	49
Basic Vehicle Control Skills Test	51
On-Road Driving Test	53
Conclusion.....	55

DISCLAIMER

This manual is only a summary of South Carolina laws and regulations. The SC Department of Motor Vehicles, SC law enforcement, and SC courts follow the full and exact language of the law contained in the South Carolina Motor Vehicle Code of Laws at <https://www.scstatehouse.gov/code/title56.php>.

This is a supplement to the South Carolina Driver's manual, which covers rules of the road, signs, signals, roadway markings and safe driving practices.

PURPOSE OF THIS MANUAL

This manual contains the information needed to qualify for a driver's license for non-commercial class E and F vehicles.

This manual is also a handy reference for people who currently drive a recreational vehicle (RV) or large non-commercial vehicle, or pull non-commercial recreational trailers, fifth-wheel trailers including livestock trailers, and motorcycle trailers. It concentrates on the information needed to drive these vehicles safely.

An RV provides a mobile living experience. Large non-commercial vehicles, motor homes, campers, and van conversions offer a way to enjoy leisure time.

The SC Department of Motor Vehicles (SCDMV) is concerned with the safe operation of RVs, recreational trailers, and large non-commercial single units and combination units. Most drivers have experience in driving passenger vehicles. However, an RV or large non-commercial vehicle handles differently. Some of the most noticeable differences are restricted vision and added braking time needed to stop. Other differences include being aware of bridge heights, buildings with low canopies, space requirement needs, increased following distances, increased turning radiuses, and the additional space needed for lane changes.

LICENSE CLASSES AND REQUIREMENTS

Non-commercial License Classes:

The size of the vehicle you wish to drive or the weight of the trailer you wish to tow determines which driver's license class is right for you. No passenger vehicle, pickup truck, large non-commercial vehicle, or RV may tow more than one other vehicle without a commercial class A license with the proper endorsement.

You may drive these non-commercial vehicles with a class E license

- | |
|--|
| <ul style="list-style-type: none">• Single unit vehicles over 26,000 pounds gross vehicle weight (GVW) that do not meet the definition of a class A, B or C license. No towed unit allowed.• Passenger vehicles. Towed unit allowed.• Mopeds• Three-wheel vehicles (excluding two-wheel motorcycles with a side car) |
|--|

You may drive these non-commercial vehicles with a class F license

- | |
|--|
| <ul style="list-style-type: none">• Combinations of vehicles with a GVW in excess of 26,000 pounds that do not meet the definition of class A, B, and C license. Towed unit allowed.• Single unit vehicles over 26,000 pounds GVW that do not meet the definition of a class A, B or C license. Towed unit allowed.• Passenger vehicles. Towed unit allowed.• Mopeds• Three-wheel vehicles (excluding two-wheel motorcycles with a side car) |
|--|

Reference SC's Commercial Driver's License Manual for the definitions of class A, B, and C licenses.

EQUIPMENT AND OPERATING CONTROLS

Safe operation of your vehicle depends on your familiarity with the vehicle. Take the time to learn from the dealer or seller how each system works and study your owner's manual.

Headlight Use

You must turn on your headlights from a half-hour after sunset to a half-hour before sunrise or if snow, rain, fog, or other hazardous weather condition requires the continuous use of windshield wipers, or when visibility is not sufficient to clearly see a person or a vehicle for a distance of 500 feet.

You may not drive any vehicle with only parking lights on.

Tires and Wheels

Tires on your vehicle must be of the proper size and correctly inflated for the load you are carrying. All tires on the vehicle should be of the same size, type, and construction. Check tire pressure when the tires are cold. Under-inflation reduces fuel economy and load carrying capacity. It may also cause control problems and can result in overheated tires and blowouts. Over-inflation increases tire wear, affects handling, and can result in blowouts. Make sure dual tires do not touch.

Running on a flat tire can cause tire fires and are a danger on vehicles equipped with dual tires. Tire fires are very difficult to put out, so inspect your tires frequently.

Wheels must be compatible with tires and should be replaced if bent, heavily rusted, or if wheel fasteners continually loosen. Improperly balanced wheel/tire

combinations will cause excessive vibrations, tire wear, and possible damage to your vehicle.

Exhaust System

Exhaust gases are deadly because they contain carbon monoxide. Any time you suspect that exhaust fumes are entering the passenger compartment, determine the cause and have it corrected as soon as possible. You should tightly close rear doors and rear windows while driving to avoid drawing exhaust gases into the vehicle.

Mirrors

The most notable difference to first-time RV operators or non-commercial large vehicle operators is the need to use side-mounted mirrors for rear vision. Backing an RV or non-commercial large vehicle may also be a new experience. It may appear difficult, but a little practice will help you become competent when backing the RV or non-commercial large vehicle, especially if you are towing a trailer.

Left- and right-hand outside mirrors are required on the towing vehicle if the RV, non-commercial large vehicle, or trailer obstructs the driver's rear vision. Make sure the mirrors are large enough and that you positioned them for vision at least 200 feet to the rear of the vehicle with a separate convex mirror mounted below. You need the mirrors to do more than back the vehicle. Check your mirrors frequently for traffic conditions behind you so you can avoid last minute maneuvers and surprises. Mount the mirrors as wide apart as possible for maximum rear vision and easy backing. Trailer towing mirrors should be adjusted so that the inside edge of the mirror is further out than the outside edge of the trailer. The RV or large non-commercial vehicle rear wheels

should be visible in the convex mirrors to check for correct tracking.

Use your mirrors to get a good idea of the size of your vehicle. Larger vehicles need more space to turn without running over curbs or sideswiping stationary objects.

Rear-Looking TV Systems

Some RVs and motorhomes are equipped with rear-looking closed circuit television systems to help you back your vehicle. You should use the closed circuit TV system in conjunction with your mirrors. The more you practice using the closed circuit TV system for backing your vehicle, the more proficient you will be.

LOADING AND OVERLOADING INFORMATION

It is almost impossible to overload a passenger vehicle because space tends to limit the amount of weight you can carry. You cannot take your child's six friends to the baseball game if you are taking all of the team's Little League equipment in the back seat. Space, not weight, is the main concern.

Now that you intend to operate an RV or large non-commercial vehicle, you must remember this type of vehicle is heavier than a passenger vehicle, and you can overload it. Also, the storage capacity in most RVs and large non-commercial vehicles offers any number of possibilities for improper weight distribution. The way you load your supplies can have a major impact on how the vehicle handles, as well as on the durability of your tires. The results of overloading can be serious. Passenger safety is at stake. Problems such as tire failure and/or poor handling can leave the driver with inadequate ability to control the vehicle during emergency maneuvers.

Load Ratings

RV and large non-commercial vehicle manufacturers provide load ratings on certification tags at various points inside or outside the RV or large non-commercial vehicle. The certification tags are usually placed as follows (if you cannot locate the sticker, check with your dealer):

- Motor homes: on door edge/pillar or near the driver's position in the interior
- Pickup/Camper: on back exterior wall
- Large non-commercial vehicles: on front left-side exterior wall
- Tow Vehicles: on driver's side doorframe

To weigh your RV or large non-commercial vehicle, you will need to use a level, commercial platform scale to obtain the following five weights (refer to the yellow pages of your local telephone directory under "Scales—Public"):

1. The entire vehicle with all wheels on the scale
2. The front axle with only the front wheels parked on the scale
3. The rear axle with only the rear wheels parked on the scale
4. The left side with only the left front and back wheels on the scale
5. The right side with only the right front and back wheels on the scale

Overloading can affect springs, wheels, axles, and tires. Tire failure can be disastrous in an RV or large non-commercial vehicle, especially at high speeds. Be very careful and pay close attention to the inflation pressures stamped on the sides of the tires.

Distribute weight as equally as possible on the left and right sides of your RV or large non-commercial vehicle. The need for this will be clear when turning and maneuvering these type of vehicles in traffic.

Pickups with campers present another type of weight distribution problem because the camper is added to the truck as cargo, rather than being built on its own chassis or being towed. Gross vehicle weight rating (GVWR) and gross axle weight rating (GAWR) listings still apply. Manufacturers are also required to tell you the weight distribution limits, or "center of gravity zones" which are listed in truck and camper owner's manuals. The main focus in balancing a camper is to

be sure the weight of the camper does not make the vehicle fishtail or top heavy and cause stability problems.

DRIVING TECHNIQUES

It's fun traveling with an RV or large non-commercial vehicle as you explore the different regions of the country. However, it can be dangerous if you are not familiar with the differences in weight, size, and visibility these type of vehicles demand of your driving. The transition from driving the family car to driving large non-commercial vehicle or an RV is different, but not necessarily difficult.

Driving requires all drivers to think ahead. This is even more important for RV and large non-commercial vehicle drivers than for drivers of passenger vehicles. An RV or large non-commercial vehicle driver must be continually aware of the traffic around the vehicle because directional changes are slower and the RV or large non-commercial vehicle needs more space in traffic. Try to avoid roads during rush hour traffic. If you are driving in unfamiliar areas, ask someone (possibly one of your passengers) to help you with directions and always have a map of the area. If you are driving by yourself, always pull off the road at a safe place and stop the vehicle before looking at a map.

The additional weight, height, width, and length of an RV or large non-commercial vehicle makes it less maneuverable than a passenger vehicle. A safe maneuver in your family car may be dangerous in an RV or large non-commercial vehicle. Since it is heavier, an RV or large non-commercial vehicle may not stop as quickly so you will need more following distance. Defensive driving in this type of vehicle requires making changes slowly, braking gradually, and being familiar with its handling characteristics.

Height Clearance

Most RVs and large non-commercial vehicles are taller than passenger vehicles so you will need to learn quickly about the height clearance of roads, service station canopies, bridges, and to watch for low-hanging obstacles such as tree branches. Your owner's manual, dealer, and manufacturer are the best sources for helping you determine the maximum road height for your RV or large non-commercial vehicle. Once you know the maximum road height, post it somewhere on the RV or tow vehicle so it will always be handy as a reference.

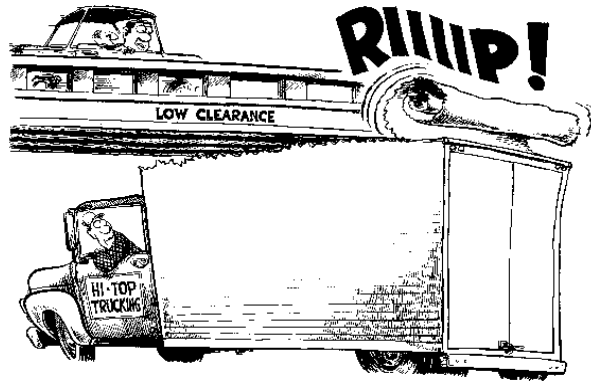

Be Prepared

Listen to the local radio stations where you are traveling. Be aware of traffic slowdowns, collisions, road construction, or any other condition that may impact your trip. If you are prepared and have a map, you will be able to take alternative routes.

South Carolina Hands-Free and Distracted Driving Act

While operating a motor vehicle on any public road within this State, individuals must not:

- Physically hold or support a mobile electronic device with any part of their body,

- Read, write, or send any form of text, which includes, but is not limited to, text messages, emails, interactions with applications, or information from websites,
- View moving images, including, but not limited to, videos, movies, games, or video calls.

This law does not restrict the use of earpieces or wrist worn devices for the purpose of conducting voice-based communications.

Penalties for violating the Hands-Free and Distracted Driving Act:

- First Offense: \$100 fine
- Second and Subsequent Offenses: \$200 fine and two points on your driving record

Safety Belts

Always wear your safety belt when driving. Even though many RVs accommodate passengers in places (i.e., dining table) where federal law does not require the area to have a safety belt—wear it. Riding in a place which is not equipped with a safety belt increases the danger of injury in case of a collision.

Fatigue

Driving is not as easy as it appears. Break up your driving time by taking a 15 to 30 minute rest every two-to-three hours. Get out of your vehicle and walk around. This will help to loosen tired muscles and rest tired eyes. Use this time to inspect your vehicle. It will also improve your alertness.

Night driving can be especially hazardous since the body naturally wants to sleep at night. Most drivers are less alert at night, particularly after midnight. If you are sleepy, the only safe cure is to get off the road and get

some sleep. If you don't, you are risking your life and the lives of others.

Weather Conditions

Bad weather conditions such as wind, fog, snow, and ice are hazards to all drivers. An RV or large non-commercial vehicle driver has an advantage over drivers of other passenger vehicles because of the added weight over the drive wheels. This gives the vehicle better traction in bad weather. However, its added weight can also make it more difficult to move if it gets stuck. Plan your trips to avoid bad weather conditions as much as possible.

Remember, if hazardous weather conditions require the use of windshield wipers you must also turn on your headlights.

Winds

If you are driving in areas with strong winds, take special care. Crosswinds are the greatest threat. They can push a large motor home or a vehicle and trailer combination into another lane if you are not prepared. This is especially true for travel trailers. In most cases, going slower is the best defense against strong winds. If you are towing a trailer, you should gradually apply the trailer brakes to help control a swaying trailer. Headwinds require a heavier throttle to maintain usual speeds. You may be able to control an RV or large non-commercial vehicle in strong winds, but the safest thing to do would be to pull over and wait it out. If you anticipate driving in very windy areas, call and obtain local weather and road conditions. Good sources of weather information are local airports, highway patrol, state police, or ranger stations. Often, you will see signs along the highway that show radio frequencies for weather information.

Snow

Always carry drive wheel and trailer wheel chains when you travel in snowy areas. Know how to put them on. The tow vehicle and one axle of the trailer need a set of chains. If you have a motor home with dual-rear wheels, you will need chains for one tire on each side.

Ice

If you are towing a trailer on icy roads, go slowly, especially downhill. Use the lower gears. You may be able to gain additional traction for the tow vehicle by moderately releasing the tension of the load-equalizing hitch. Always readjust the hitch after the icy road condition has passed because normal driving conditions may still affect vehicle stability.

Traveling on a Holiday

Proper planning can help reduce much of the holiday traffic congestion. Many campsites accept reservations. Since roads leading to many popular attractions will be crowded, you may want to plan on a different route. If you haven't made reservations, it's a good idea to stop early in the day to ensure you get a campsite, because private and public campgrounds fill up quickly. Get a good rest before traveling.

Starting and Shifting

Always try to start and shift (for manual transmissions) smoothly to prevent wear and tear on the hitch and transmission systems.

In each gear, you must build up sufficient speed to avoid lugging the engine in that gear, and speed must be sufficient so that the engine will not be lugged when the next higher gear is reached.

You may use double clutching on most manually shifted truck transmissions except synchromesh transmissions. Shifting is faster and smoother when this procedure of depressing the clutch twice with each change of gears is used.

Be alert to changing conditions that may require a reduction of speed and shifting down a gear. Do not wait until the engine starts lugging before shifting down. For dangerous downgrades, the gears should be downshifted to make use of engine braking.

A good driver will downshift before passing the crest of a hill since it is dangerous to downshift past this point. Missing a gear can be dangerous.

If your brakes fail on a level road, you should shift to a lower gear and use engine compression to assist you in stopping the vehicle.

Signal Your Intentions

Always use your vehicle's mechanical signals when you move through or out of traffic. In an emergency, and once you are on the side of the road, use emergency flashers, flares, or some other emergency signaling device to warn oncoming traffic. Emergency signaling devices are even more important if you are unable to pull completely away from the flow of traffic, on the top of a hill, or around a curve in the road where other drivers cannot see you.

If you have a flat tire, make sure the person who changes the tire is not in the way of oncoming traffic. If the driver cannot park the vehicle far enough away from traffic flow, use safety precautions such as emergency signaling devices and a person to flag

traffic away from the scene. Be sure the jack is adequate to lift the vehicle and the wheels are blocked.

Braking

Most RVs and large non-commercial vehicles are heavier than passenger vehicles and require greater braking distances. You must allow more time for the vehicle to slow or stop. If you are towing with an RV or large non-commercial vehicle, you must also worry about brake fade. Brake fade can happen when the brakes overheat from prolonged use or the brakes are out of alignment. To help avoid brake fade on downgrades, use the lower gears to allow the engine to help slow the vehicle.

Speed

RVs and large non-commercial vehicles are naturally slower than passenger vehicles. It takes longer to climb a hill in an RV or large non-commercial vehicle because it's heavier than a passenger vehicle. Keep this in mind, practice good manners, and observe the law by using turnouts when there are five or more vehicles behind you that wish to pass. The drivers behind you will be able to see ahead more easily if you try not to drive next to the center of the lane. If you are traveling with other RVs or large non-commercial vehicles in a caravan, be sure to leave enough space between your vehicle and the vehicle in front of you for other drivers to enter when they want to pass.

Collisions

Good defensive driving techniques will help you from becoming involved in collisions. One important technique is to keep a three-second or more following distance from the vehicle ahead of you. Keeping your distance gives you time to react and avoid a collision.

Following Other Vehicles

You should make a habit of never driving too closely behind other vehicles. Allow enough space between you and the vehicle ahead that you can stop easily and safely in an emergency. Always keep in mind adverse conditions such as weather and roads; traffic conditions may require more cautious driving.

Leave enough space between you and the vehicle ahead to allow faster traffic to pass you and return to the right lane. Whenever conditions permit, you should not follow a motor vehicle closer than 300 feet. SC Code Section 56-5-4780 requires that you dim your headlights when approaching another vehicle from the rear within a minimum of 200 feet.

Plan Your Escape

To successfully avoid a collision, you need to plan your escape. As a defensive driver, you already prepared for this by maintaining a space cushion around your RV or large non-commercial vehicle, which you will need to avoid an emergency. Glance at the shoulder of the road. Does it look firm and wide enough to support your vehicle? Is your vehicle well maintained so that you don't have to worry about unexpected mechanical problems? Remember to make gentle steering movements.

Emergency Stops and Warning Signals

When your vehicle is disabled and you cannot move it off the traveled portion of the roadway, you must put out emergency signals.

Emergency warning signals may be red flags, pot torches, reflector flares, reflective triangles, red electric lanterns, or fuses.

When necessary to stop in the daytime, put out red flags or reflective triangles as follows:

1. Place a warning device at least 100 feet but not more than 500 feet in the center of the lane, both in front of and behind the stopped vehicle.
2. On a divided highway or one-way roadway, place one warning device at least 200 feet to the rear of the stopped vehicle and one at a distance of 100 feet to the rear, in the center of the lane. When visibility is restricted to less than 500 feet due to fog or similar conditions, use the signals specified for night use.

When necessary to stop at night, immediately turn on your four-way flasher to make the turn signals on both sides of your vehicle flash simultaneously at the front and rear and then place reflective triangles, reflective flares, red electric lanterns, or fuses as follows:

1. On a straightway, place one warning device on the traffic side, ten feet to the rear of the vehicle.
2. Next, a warning device at least 100 feet behind the stopped vehicle, in the center of the lane.
3. Another warning device 100 feet ahead of the stopped vehicle, in the center of the lane.
4. One additional warning device, if available, on the traffic side, ten feet from the front of the vehicle.

5. On a divided highway or one-way roadway, one signal 200 feet and one 100 feet to the rear, in the center of the lane, and one at the traffic side of the vehicle ten feet to the rear.

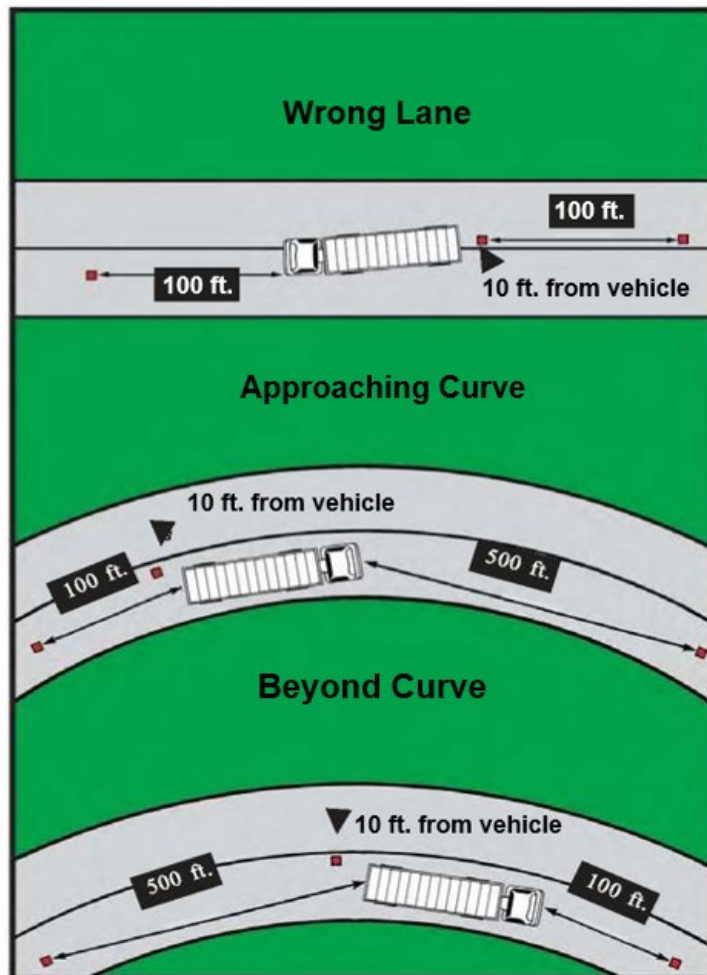

Fires

All RVs should carry at least one dry chemical or carbon dioxide (CO₂) type extinguisher in working condition with

a rating of at least 4-B. The most effective fire extinguishers use halon gas and are good investments for RV safety. It can keep a small, manageable fire from becoming a major, uncontrollable fire.

The best fire protection includes:

- Proper maintenance and inspection of fuel systems and electrical equipment
- Use of a smoke detector
- Use of a liquefied petroleum (LP) gas detector

Make sure the fire extinguisher is suitable for the type of fire and is large enough to put out the fire. If you have a fuel or electrical fire, first try to shut off the source of the fuel by turning off the fuel valves and unplugging the electrical circuits. If you aren't sure what type of fire it is, shut off everything. All family members should be able to put out a small gas or oil fire with the extinguisher.

The most common extinguisher is a 2 ½ pound ABC (defined below), which is suitable for all types of fires, including fuel fires and electrical fires. There is no substitute for the correct type of fire extinguisher. The letter designates the type of fire suitability:

- A - Ordinary materials like wood and paper
- B - Petroleum products such as gasoline, propane, and kerosene
- C - Electrical

Be sure to recharge the extinguisher after it is used, even if it is not totally empty. You should recharge conventional CO₂ extinguishers periodically even if they are not used. The dry powder used in CO₂ extinguishers tends to compact with road vibration. Every month, you should turn a dry powder or dry

chemical extinguisher upside down, shake it a few times, and tap on the bottom so that the powder is kept loose.

Put the extinguishers where fires are most likely to occur and where you can easily reach them. For example, with a tow vehicle and travel trailer, you should have an extinguisher in the tow vehicle and another near the kitchen in the trailer.

Fuels

RVs normally carry two types of fuels: gasoline and propane, although some RVs use diesel and propane. Very few do not have propane on board.

Propane is no more dangerous to use than gasoline or diesel. All three fuels, if mishandled, can cause disaster. Propane vapor is just as explosive as gasoline or diesel vapor. When propane leaks from one of the lines inside an RV, the volume can build up to the point where it may explode. Leaking gasoline can also cause an explosion if its vapor collects in a closed area. Of course, a source of ignition must be present to set it off. In any case, both fuels deserve respect. Knowledge and preventive maintenance are the keys to safety.

Make frequent inspections of your large non-commercial vehicle's or RV's fuel systems. Look closely to see if lines are rubbing against sharp edges of the vehicle. Check to see: Is the neoprene (synthetic rubberlike plastic) gasoline line cracking because it is old? Is the carburetor starting to leak? Do the joints in the propane lines have a leak? Wash the propane lines with soapy water, and if bubbles appear, there is a leak.

Routine Driving Tasks

Many of the routine driving tasks that you face in driving a truck or RV will be similar to driving a car. For the sake of all road users, it is important to be a defensive driver when driving any vehicle.

Curves

Maneuvering around curves and turns in trucks and RVs requires more skill and care than in cars. The driver must always execute curves and turns at a reduced speed consistent with the available sight distance, the sharpness of the curve or turn and other prevailing road and traffic conditions.

On sharp or right curves, you must lead the turning arc of the front wheels in keeping with the sharpness of the curve and the amount of off-track of your vehicle. On a curve to the right, you must keep your front wheels close to the centerline to prevent dropping the rear wheels off the pavement or breaking the pavement shoulders. On a curve to the left, you must keep your front wheels close to the right edge of the pavement to prevent the rear wheel from crossing into the other traffic lane.

When entering a curve, you must make sure that the speed of your vehicle is slow enough for you to retain control in the curve. If you apply your brakes in a curve, your vehicle may skid or jackknife. You may gradually accelerate on a curve only after you have passed the midpoint of the curve. You must enter a curve at a speed that doesn't require braking. Failure to do so greatly increases the chances of "rolling-out", skidding, or jackknifing.

Turning Patterns

Longer wheelbases make it necessary to change your turning patterns. You must turn wider at intersections or

the rear wheel may roll over the curb. Go further into the intersection before starting the turn and adjust your lane position to increase the turning radius.

Curves in the highway can also be tricky. Stay to the center of the lane for right turns so the rear wheels will not go off the pavement. For a left turn or curve, stay to the right of the lane to prevent the back of the trailer from tracking into the oncoming lane of traffic.

RVs and some large non-commercial vehicle have a high center of gravity, so you must turn corners and take curves at slower speeds to prevent swaying. Slow down before you enter the curve.

If you transport livestock, be careful because they can move around in a trailer. This shifts the center of gravity and makes a rollover more likely. With less than a full load of livestock, use barriers to keep the livestock together. Even then, be very careful in curves. Livestock will also lean in the curve and this could cause a rollover if you are driving too fast.

Turns

1. Know where you want to turn ahead of time. Never make a last-minute decision. Check both mirrors for other vehicles and pedestrians to determine if it is safe.
2. It is important to signal your intentions 100 feet before turning. Be sure your signal light is off after completing the turn. Failure to do so tends to create confusion for other drivers.
3. There will be times when faster moving traffic will require you to move into the proper lane much sooner than you ordinarily would in order for you to make a safe turn.

4. Be sure to follow the pavement markings when possible and finish your turn in the proper lane.
5. A major concern while turning will be your “off-track.” On any turn, the rear wheels will follow a shorter path than the front wheels. The illustrations will give a clear understanding of your off-tracking position.
6. When executing a right turn, be sure your rear wheels do not run up on and over the curb.

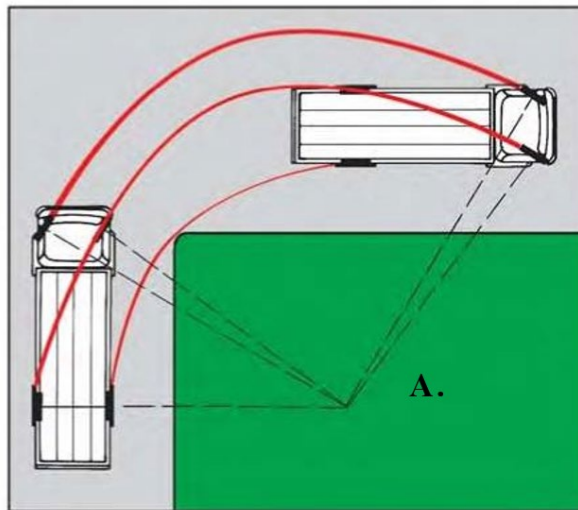

In illustration A, notice the rear wheels of the single-unit vehicle follow a shorter path than the front wheels.

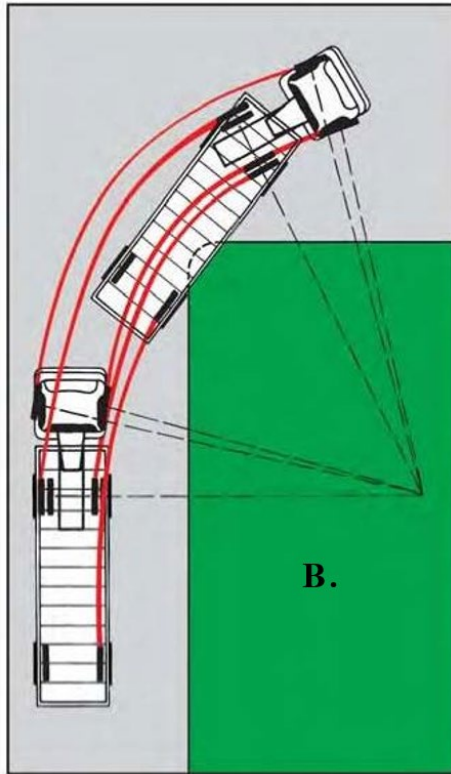

In illustration B, notice the rear wheels of the trailer follow shorter paths than the front wheels of the RV or large non-commercial vehicle.

Right Turns

1. Single-unit vehicles must signal 100 feet before the turn and enter the turn as near to the right curb as possible. Operators of large vehicles must bear in mind that the off-track of the rear wheels will follow a shorter path than the front wheels. You must allow for this on all turns so that your vehicle does not strike another vehicle or a stationary object. Be careful about swinging wide to make a right turn. There is danger that some other driver will try to pass on the right. If you must make a wide turn, you should make the swing wide into the street you are entering.

2. Combination vehicles follow the same procedure in turning as single-unit vehicles, except that the off-track will take a shorter path while turning and the swing-out must be greater. A hazard of the swing-out is the possibility of a vehicle passing on the right. There will be times when you'll have to stop and allow other vehicles to clear the lanes that you are about to enter.

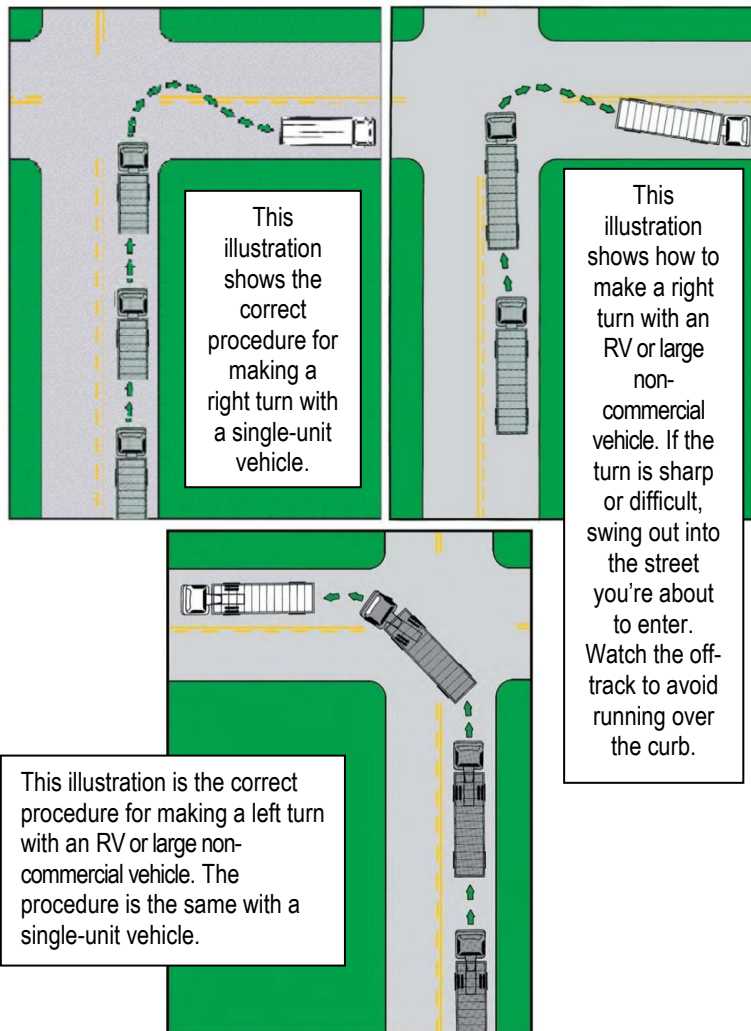

Left Turns

Slow down when making a left turn. You must get into the lane nearest the centerline. Make sure no one is attempting to pass you. Look for traffic approaching toward you and to the left and right. Your vehicle should be just to the right of the centerline as you make your left turn. Watch your off-track while you are turning.

Interstate Driving

You will have slower acceleration when you enter an interstate, so you will need more space. Remember that interstate traffic has the right-of-way, so you must look for gaps large enough to accommodate your vehicle(s). You also need more space when passing other vehicles. Judging how much space you will need takes practice. If you don't allow enough space and time to complete a pass, you may need to swerve quickly into another lane. This could result in a skidding, oversteering, swaying, or fishtailing trailer.

You must also increase your following distances because you cannot slow down and stop your vehicle quickly. When you want to exit an interstate, slow down sooner than you would for a smaller vehicle. Be aware that many off ramps have curves, which continually tighten. You will need to stay to the outside of the curve so the rear wheels will not rub the curb or drop off the pavement.

Best driving practices recommend that slower vehicles stay in the right-hand traffic lane or as close as possible to the right edge or curb. If you drive on a divided highway with four or more traffic lanes in the same direction or where there are no specific lanes designated, you can drive in the lane just to the left of the right-hand traffic lane. When overtaking or passing another vehicle going in the same direction, you must

use either: (1) the designated lane, (2) the lane just to the left of the right-hand lane, or (3) the right-hand traffic lane when use of that lane is permitted.

Passing

1. You should only attempt passing when you have clear and adequate space ahead to complete the pass without racing and without risk to yourself or the vehicle you are passing.
2. You must give a signal 100 feet before pulling out to pass. Signal before returning to the right-hand lane when changing lanes.
3. Return to your lane when you can see both headlights of the vehicle you are passing in your side-view mirror.
4. On multiple-lane highways, don't pass if you would block faster traffic overtaking from the rear.

Being Passed

1. When being passed by another vehicle, keep well to the right side, maintain your speed and, if necessary, reduce speed to facilitate safe passing. Never speed up to prevent another driver from passing.
2. Do not signal the driver of an overtaking vehicle that is safe to pass. This is a dangerous practice and the U.S. Department of Transportation prohibits it. To give such a signal transfers part of the responsibility for safe passing from the overtaking driver to yourself. If an accident occurs after you have given a signal, you could be held liable for any damages.

3. Be alert for the driver who tries to pass in an unsafe place. Don't try to block the passer and be ready to do anything that may be necessary to avoid being involved in an accident.
4. At night, dim your lights after you are passed to avoid creating a glare in the other driver's mirror.

Meeting Other Vehicles

1. Always keep to the far right when meeting any oncoming vehicle. At night, dim your headlights 500 feet from any oncoming vehicle regardless of any action its driver may take.
2. If you see a vehicle approaching on your side of the road, slow down and pull as far to the right as safely as possible and stop. Never pull to the left in an attempt to avoid an oncoming vehicle in your lane.
3. When it is safe, return to the right-hand lane.
4. Never attempt to pass a vehicle when approaching the top of a hill, curve, intersection, side road, bridge, railroad crossing, or any place where you do not have a clear view of the road ahead. Make sure you can see the traffic approaching from the side.
5. You must pass standing buses in accordance with local traffic regulations.
6. Be alert for school buses and ready to make a safe stop if necessary. You must stop for a the entire time a school bus is stopped or preparing to stop with its red or amber lights flashing or its stop arm extended. After the school bus's red and/or amber lights have stopped flashing and the stop arm is no longer visible, proceed slowly, watching for children. Law requires these

actions whether you are meeting the bus or traveling behind it under the following conditions:

- a) On any two-lane highway
 - b) On any four-lane or multi-lane highway only when traveling behind a school bus
 - c) When passing a school bus that has red or amber signals flashing
7. Do not attempt to pass unless there is sufficient difference between your speed and the speed of the slower vehicle so that you can pass without delay.
 8. Do not attempt to pass more than one vehicle at a time. If you try to pass a line of traffic, you may find yourself in a position where you cannot return to the right lane should the need arise.
 9. On multiple-lane highways, take care not to pass when you would block faster traffic overtaking from the rear. On highways with three or more lanes of traffic in the same direction, use only the two right-hand lanes unless passing or when making a legally permitted left turn.

Mountain Roads

Will your vehicle make it up the grade? Almost all grades, regardless of severity, will cause you to slow down. Any grade steeper than six percent is considered extreme and requires special attention. The steeper or longer the grade and the heavier the load, the more you will have to use lower gears to climb hills or mountains.

When going down steep hills, gravity tends to speed you up. You must select an appropriate safe speed, use a low gear, and apply enough braking power to hold you back without letting the brakes get too hot. Use the braking effect of the engine (lower gears) as the principal way of controlling your speed to save your brakes so you will be able to slow or stop as required by road and traffic conditions. Slow the vehicle and shift the transmission to a low gear *before* starting down a grade.

The use of brakes on a long and/or steep downgrade is only a supplement to the braking effect of the engine. Once the vehicle is in the proper low gear, the following is a proper braking technique:

1. Apply the brakes just hard enough to feel a definite slowdown.
2. When you have reduced your speed to approximately five miles per hour below your "safe" speed, release the brakes. This brake application should last for about three seconds.
3. When your speed has increased to your "safe" speed, repeat steps 1 and 2.

Do not drive in the fast lanes on a multiple-lane grade. Stay in the far right lane while climbing a steep grade if your RV or large non-commercial vehicle will not maintain the legal speed limit. It would be better to drop to a lower gear and slow down rather than pass slow trucks and tie up the faster lanes because you don't have enough power.

Escape Ramps

Escape ramps have been built on many steep mountain grades, and are used to stop runaway vehicles safely without injuring drivers and passengers. Escape ramps use a long bed of loose, soft material

(pea gravel or sand) to slow a runaway vehicle, sometimes in combination with an upgrade.

Know where escape ramps are located on your route. Signs show drivers where ramps are located.

Narrow Roads

Some two-lane roads have special "turn-out" areas. You may pull into these areas and allow vehicles behind you to pass. Some two-lane roads have a passing lane. Stay in the right lane so faster vehicles may pass you in the passing lane. When you drive a slow-moving vehicle on a two-lane highway or road where passing is unsafe, and five or more vehicles are following you, pull to the side of the road wherever you can safely do so to let the vehicles pass.

Try to stay to the right of the lane so the vehicles behind you can see ahead. Remember to pull off the road when it is safe and allow the faster vehicles to pass.

Road Signs

Pay attention to road signs that warn against travel by vehicles towing trailers. If you missed the sign that warned of a "Dead End" ahead, would you be able to turn your vehicle around? What was the weight limit for the bridge ahead? Did you notice the height clearance for the overpass? You may not notice these types of signs because you've never had to worry about them in your passenger vehicle. *You will have to worry about them in your RV or large non-commercial vehicle.*

Dirt or Unpaved Roads

Many times the only road into the campground is a dirt or gravel road. Consult a campground directory to see if a certain road is suitable for your vehicle. Pay close attention to the signs posted and believe them. If a sign

prohibits trailers, don't use that road. There may be a hazard such as rocks, low trees, or washed-out sections of the road ahead that only a four-wheel drive vehicle can handle safely.

Handling Emergencies

All drivers have emergencies at some point. Although you can't avoid emergency situations, you can mentally prepare for them. Think about emergency situations and decide how you would handle them so you will be better prepared to react properly if they really happen.

TOWING SAFELY

Towing Cars or Other Vehicles

Towing small cars behind an RV or large non-commercial vehicle has become a popular way of providing transportation after you park the RV or large non-commercial vehicle at a campsite, for example. Towing a car differs from towing travel trailers or fifth-wheel trailers. Very little hitch weight is involved when the car is towed on all four wheels and only minimal hitch weight is involved when the car is towed on a dolly.

If you wish to tow a vehicle behind your RV or large non-commercial vehicle, you need to consider whether it can handle the extra weight under all conditions (i.e., climbing steep hills or mountains). Your vehicle must have sufficient power to climb grades without holding up traffic and its braking power must be sufficient to stop the combined weight of the RV or large non-commercial vehicle plus the car and/or tow dolly effectively. RV chassis manufacturers provide limits on the gross combined weight of the RV plus car. This is also true for large non-commercial vehicles.

If you are towing a car, be sure the hitch attachment on the RV or large non-commercial vehicle is secure. Hitch weight ratings are usually stamped on the hitch assemblies. The tow bar attachment is also a concern because of the integrated frame construction used in most small cars. If you use a tow bar, safety chains are required, but a breakaway switch is not. Fully operational tail, brake, and turn signal lights are required on the towed car.

It's easy to forget you are towing a car when driving an RV or large non-commercial vehicle because you cannot see it. So remember to allow extra space when entering

an interstate or passing another vehicle so you won't cut off the other driver. Your vehicle combination cannot exceed 65 feet.

One other thing to consider—you may only tow one vehicle with your class F driver's license. You may **not** tow two vehicles or trailers with a class F license.

Example: You **cannot** tow a boat trailer and a car behind your vehicle.

Towing a Trailer

Perform a safety inspection before each trip. Make sure that:

- The pin securing the ball mount to the receiver is intact
- You secure the hitch coupler
- Spring bar hinges are tight with the safety clips in place (load equalizer or weight distributing hitches)
- You properly attach safety chains
- You properly install the electrical plug

People who tow trailers share the same safety concerns as other RV and large non-commercial vehicle drivers. However, a tow vehicle and a trailer form an articulated (hinged) vehicle, which presents an additional set of concerns. The tow vehicle must be a proper match for the trailer. If the trailer is properly equipped, it can perform safely under a variety of driving conditions. The tow vehicle should also have enough power to climb mountain grades without excessive loss of speed. There are three basic types of trailers, which mostly differ in the way they are hitched:

1. Conventional travel trailers, including folding camping trailers
2. Fifth-wheel trailers
3. Motorcycle, tent, and cargo trailers.

The biggest problem with towing a motorcycle trailer is loading it so there is equal weight on each wheel. The less unused space in your trailer, the less load shifting problems you will have. If you carry an ice chest inside the trailer, be sure to pack it over the axle. If you carry the ice chest on the trailer tongue, load it at the same time you load the trailer to obtain the proper tongue weight. Remember to readjust the weight as you use the contents of the ice chest to maintain proper tongue weight. Loading your motorcycle saddlebags will also assist with traction and handling when towing a motorcycle trailer.

Pack frequently needed items last so they will be at the top of the trailer. Never overload the trailer beyond the GVWR.

Conventional Trailers

A wide variety of tow vehicle and trailer combinations use the ball and coupler hitch. This hitch consists simply of a ball attached to the rear of the tow vehicle and a coupler (socket) at the tip of a tongue or A-frame attached to the front of the trailer. Recreational trailers commonly use this hitch.

Heavier models such as utility trailers, boat trailers, and travel trailers use a load-distributing hitch. These load-distributing hitches use special equipment to distribute the tongue load to all axles of the tow vehicle and trailer to help stabilize the tow vehicle. Here are some terms you should know when discussing hitch adjustment and in evaluating hitch performance:

- **Receiver:** Hitch platform fitted to the tow vehicle.
- **Ball Mount:** A removable steel component that fits into the receiver. The hitch ball and spring bars (only on load-distributing hitches) are attached to it.
- **Sway Control:** A device designed to lessen the pivoting motion between the tow vehicle and trailer when a ball-type hitch is used.
- **Coupler:** The ball socket at the front of the trailer A-frame that receives the hitch ball.
- **Spring Bars:** Load-leveling bars used to distribute hitch weight among all axles of the tow vehicle and the trailer in a load-distributing ball-type hitch.

Fifth-wheel Trailers

People do not give as much attention to balance, hitching procedures, and weight restrictions for fifth-wheel trailers because they are typically very stable. A disadvantage that a fifth-wheel has over conventional trailers is that much of the truck bed space is not available. The fifth-wheel hitch occupies the center of the truck bed and the hitch pin is in front of the centerline of the tow vehicle's rear axle. The hitch weight of fifth-wheel trailers is usually around 20 percent of the trailer weight. Hitches are rated for up to 15,000 pounds of gross trailer weight. Here are some terms used to describe typical fifth-wheel hitch components:

- **Fifth-wheel Plate:** Unit that contains the hitch plate, plate jaws, and a handle mounted in the truck bed.
- **Handle:** Device used to release or lock the plate jaws.

- **Hitch Plate:** "Wheel" that allows the trailer to rotate.
- **Pin:** The connecting device attached to a fifth-wheel trailer and designed to fit into the plate jaws mounted in the truck bed.
- **Pin Box:** Structure attached to the bottom front section of the trailer frame (the pin is attached to the bottom).
- **Plate Jaws:** Holds the pin.
- **Side Rails:** Support rails which are bolted to the tow truck bed to support the fifth-wheel hitch.

Balance

Before you tow a trailer, evaluate the trailer's weight distribution. Hitch weights for travel trailers should typically be at least ten percent of the trailer's gross weight for acceptable handling. In some cases, it can go to 15 percent or higher. The capacities of the two vehicles and hitches limit the hitch weight for larger trailers. The strongest load-distributing hitch is rated for a maximum hitch weight of 1200 pounds. Most passenger car suspensions cannot handle that much weight and you should tow the trailer with a pickup truck or van. Improper weight distribution can cause the trailer to fishtail (sway back-and-forth across the lane).

Hitch Adjustment

If the hitch weight is less than ten percent of the gross trailer weight, you can compensate for some of this by loading heavy supplies such as tools and canned goods as far forward as possible. If your trailer's water tank is behind the axle(s), travel with as little water in the tank as possible to reduce weight in the rear. Trailers with water tanks located in front usually handle

best when the tanks are full, because the water adds to the hitch weight.

Be sure that the spring bars of the load-distributing hitch are rated high enough to handle the hitch weight of your trailer, plus a safety margin of at least ten percent. Check for adequate rear suspension of the tow vehicle. This means that the vehicle sits relatively level prior to hitching the trailer.

Load-distributing hitches are designed to distribute the hitch weight relatively evenly to all axles of the tow vehicle and trailer. The tow vehicle and trailer should be in a level position (altitude) in order for the hitch to do its job properly. Here is how to check:

1. With the tow vehicle loaded for a trip, measure the distance between the vehicle and the ground at reference points, which you can establish, in front and rear. Keep the figures handy for later use.
2. Hitch the trailer and adjust the tension on the spring bars so the tow vehicle remains at roughly the same attitude (i.e., if the rear drops an inch after hitching, the front should also drop an inch).
3. Inspect the trailer to be sure it is level. If it is not level, you should raise or lower the hitch ball height, as necessary. You may need spring bars rated for more weight if you cannot keep the tow vehicle from sagging in the rear.

Safety chains are required for travel trailers. Safety chains are not required for fifth-wheel trailers. The purpose of safety chains is to prevent the trailer from separating from the tow vehicle in the event of a hitch failure, such as a hitch ball that has loosened. You

should cross the chains in an "X" fashion below the ball mount, with enough slack to allow unrestricted turning, but not enough to allow the coupler to hit the ground.

Breakaway switches are also required for any trailer having a gross weight of 1500 pounds or more and manufactured after December 31, 1955. They are designed to activate trailer brakes if the tow vehicle becomes separated from the trailer. One end of the breakaway switch is attached to an electrical switch on the trailer frame and the other end is looped around a stationary hitch component on the tow vehicle. If the two vehicles separate, the cable pulls a pin inside the breakaway switch and applies full power from the trailer battery to the trailer brakes.

Even though hitch component failure is rare, the breakaway switch and the safety chains must be in good working order.

The hitch on the motorcycle trailer should be on the same plane as the rear axle on the motorcycle or slightly below. This will help prevent the trailer from pushing up on the rear end when braking. Also, the hitch should be as close to the rear tire as possible to provide a more solid support without interfering with the tire. Anchor the hitch so that two mounts are on each side. One of the two mounts on either side should resist a downward force and one of the two mounts on the other side should resist the rearward pull.

The tongue length on the trailer is generally twice the trailer wheel width but no more than six feet from the axle to the end of the tongue. Good design will allow for good sway control. If the tongue is too short, the trailer will sway. If too long, the trailer will be sluggish and cut corners when turning.

For motorcycle trailers, you should use a trailer designed for motorcycles because auto trailer tongue weights are too heavy. A trailer with a good aerodynamic design will enhance handling and performance. Maintaining a low center of gravity will improve handling as well.

Sway Control

The trailer should handle well if the weight and hitch adjustments are correct. However, the coupling between a tow vehicle and trailer should also prevent side-to-side motion for the best possible towing comfort and safety. If you detect sway in your trailer, stop to check if the load has shifted. Check for suspension problems and make sure the tires and wheels are properly secured and inflated. Be sure the trailer hitch is secure. A small reduction in tire air pressure or a slight increase in the tongue weight may help. A sway control device should be included when you install the hitch. This device helps give the tow vehicle and trailer a "one-vehicle" feel. There are two basic types of sway control systems available:

- **Friction bar** — slides in and out and the motion of the vehicle activates it. When you brake or turn, the trailer weight compresses the bar, which then compresses the trailer against the tow vehicle.
- **Dual cam sway control** — usually works better for large trailers with heavy tongue weights. You apply the cam action to the spring of the trailer to reduce sway and shifts the weight forward. It also adjusts a weight shift, which allows the trailer to follow the tow vehicle.

Trailer Lights

Trailers in South Carolina are required to have reflectors, tail, brake, and license plate lights. Signal

lights are also required if the tow vehicle's lights are hidden. Trailers over 80 inches wide must have clearance lights. Most manufacturers comply with these requirements; however, it is up to you to be sure that all lights operate correctly.

SC Code of Law Section 56-5-4510 and -4580

Trailer Brakes

In South Carolina, brakes are required on any trailer coach or camp trailer having a gross weight of 3,000 pounds or more. Usually the braking capacity on tow vehicles is good; however, it may not be good enough to safely stop the several hundred to several thousand additional pounds that your trailer weighs. Most conventional and fifth-wheel trailers have electric brakes, activated by a controller in the tow vehicle. The controller automatically coordinates the tow vehicle and trailer braking so the two systems work together when the brake pedal is applied.

The controller can also be helpful in stabilizing a trailer that sways because of bad road conditions. Manually applying the trailer brakes by using the hand lever on the controller will stabilize a trailer that is likely to sway.

Folding camp trailers and boat trailers are usually fitted with surge brake systems, which operate separately from the tow vehicle's brakes.

A mechanism attached to the receiver/ball applies the surge brakes. As the tow vehicle slows, the forward motion of the trailer compresses the mechanism, which in turn applies the trailer brakes.

Motorcycle trailers do not need brakes unless the weight exceeds 3,000 pounds gross. If you install brakes on your motorcycle trailer, be sure the brakes

do not brake harder than the motorcycle or the motorcycle may flip backwards over the trailer when the brakes are applied. You must always properly adjust the brakes.

SC Code of Law Section 56-5-4850

Trailer Backing

Backing a trailer can be frustrating for inexperienced owners. The most important thing to remember is that the trailer will go in the opposite direction of the tow vehicle. It is helpful to have another person help you back the trailer.

Here are two methods for backing trailers:

1. Turn the vehicle's wheels to the right to make the trailer go left, and vice versa.
2. Put your hand at the bottom of the steering wheel. The trailer will go in the same direction your hand moves (moving your hand to the right will cause the trailer to go right, and vice versa).

Sharp steering wheel corrections will cause the trailer to jackknife and may cause damage to the rear of the tow vehicle or the front of the trailer.

REQUIREMENTS TO GET A NON-COMMERCIAL CLASS E OR F LICENSE

These four rules apply to both class E and F driver's license applicants:

- You must be at least 18 years old.
 - You must pass the vision test.
 - You must have either liability insurance or sign a statement attesting that your household does not have a motor vehicle.
1. To obtain an original non-commercial class E license to operate **single units only 26,001 or greater GVW:**
 - You must pass the knowledge test required for a class E license at any SCDMV branch.
 - You must pass the skills test at any of the designated branch offices that administers the class E skills test.
 2. To obtain an original non-commercial class F license:
 - You must pass the knowledge test required for a class F license at any SCDMV branch.
 - You must pass the skills test at any of the designated branch offices that administers the class F skills test.
 - a) **To operate combination units with a towed unit 26,001 or greater GVW Truck with Trailer, Camper, or Travel Trailer:**
 - You will be required to perform all off-road maneuvers (basic skills test) with towed unit attached.

- You will be required to tow the unit while testing on the road (on-road test).
- b) **To operate motor home with trailer, camper, or travel trailer:**
- You will be required to perform all off-road maneuvers (basic skills test) with **a** towed unit attached, **unless towing a car with a tow bar which prohibits backing.**
 - You must be able to attach and detach unit from vehicle without SCDMV assistance.
 - You will be required to tow the unit while testing on the road (on-road test).
3. **To renew a non-commercial class E or F license:**
- You may have to pass the vision test at any SCDMV branch (beginning October 1, 2020).
 - You must have either liability insurance or sign a statement attesting that your household does not have a motor vehicle.
 - If your license is expired by nine months or more, you must complete **all** applicable knowledge and skills tests before the SCDMV can issue you a new license.
 - If you have more than five points against your license within the two years prior to renewing your license you must pass **all** applicable knowledge tests.

SKILLS TEST

You may hear a skills test called a road test.

Do not schedule a skills test until you are prepared to pass all three parts:

1. Vehicle Inspection
2. Basic Vehicle Control Skills Test
3. On-Road Driving Test

Only designated SCDMV branches administer the skills tests for class E or F driver's licenses. You may schedule a skills test on the SCDMV's public website dmv.sc.gov

You must take the test in a vehicle that represents the type of license you're applying to get. Only you and an SCDMV examiner are allowed in or around the vehicle during the test.

Vehicle Inspection

Drivers should always inspect their vehicles before each trip. It is your responsibility to make sure that the vehicle is in a safe condition.

Before taking the basic skills and/or road tests, the SCDMV examiner will lead you through a vehicle inspection to make sure all equipment is operating properly. You and the examiner will check the following items:

- Vehicle walk around
- Leaks
- Tires
- Head lights (high and low beam)
- Tail lights and brake lights
- Turn signals (front and Back)
- Horn (audible at 200 feet)
- Air brake check
- Trailer and vehicle axles
- Windshield wipers

- Step 1: With the engine running, build the air pressure up to governed cutout (100-125 psi). Shut off the engine, chock your wheels if necessary, release the parking brake (all vehicles) and the trailer protection valve (combination vehicles) and fully apply the foot brake. Hold the foot brake for one minute. Check the air gauge to see if the air pressure drops more than three pounds in one minute (single vehicle) or four pounds in one minute (combination vehicle).
- Step 2: Without restarting the engine, turn electrical power to the on or battery charge position. Begin fanning off the air pressure by rapidly applying and releasing the foot brake. Low air warning devices (buzzer, light, and flag) should activate before air pressure drops below 60 psi or level specified by the manufacturer.
- Step 3: Continue to fan off the air pressure. At approximately 40 psi on a combination vehicle (or level specified by manufacturer), the trailer protection valve and parking brake valve should close (pop out). On other combination vehicle types and single vehicle types the parking valve should close (pop out).

Basic Vehicle Control Skills Test

The examiner will ask you to perform a series of basic control maneuvers during this portion of the test. You will need to keep your vehicle within the boundaries of the course and maintain a safe moderate speed. You are required to stop anytime you see the examiner's hand raised. You are also required to set your brakes and sound your horn at the completion of each maneuver.

The Stop Line

This tests your ability to judge the position of the front bumper with respect to a fixed line. This maneuver simulates the conditions encountered in stopping at a marked crosswalk or a situation in which the driver must pull forward as far as possible in close quarters without touching a stationary object or vehicle.

Straight Line Backing

This tests your ability to keep the truck under control while moving backward with the use of mirrors. When backing a combination unit, keep the left rear corner of the trailer in sight at all times. You must back the vehicle slowly, smoothly, and as straight as possible.

Forward Serpentine

This tests your ability to maneuver your vehicle in and out of tight places. This maneuver simulates conditions that you might encounter when disabled or wrecked vehicles partially block the highway or in negotiating detours in heavy traffic or other situations.

Alley Docking

This tests your ability to back your vehicle into a narrow space and stop with the rear of the vehicle within a specified distance of the back limits of the space. This would be similar to backing up to a dock

or shipping platform between two other vehicles from a street or yard area with limited space.

Off-street maneuvers

Total length 250 feet
Width 50 feet
Alley width 12 feet
Alley length 25 feet

Each circle represents cone with stanchion and flag.

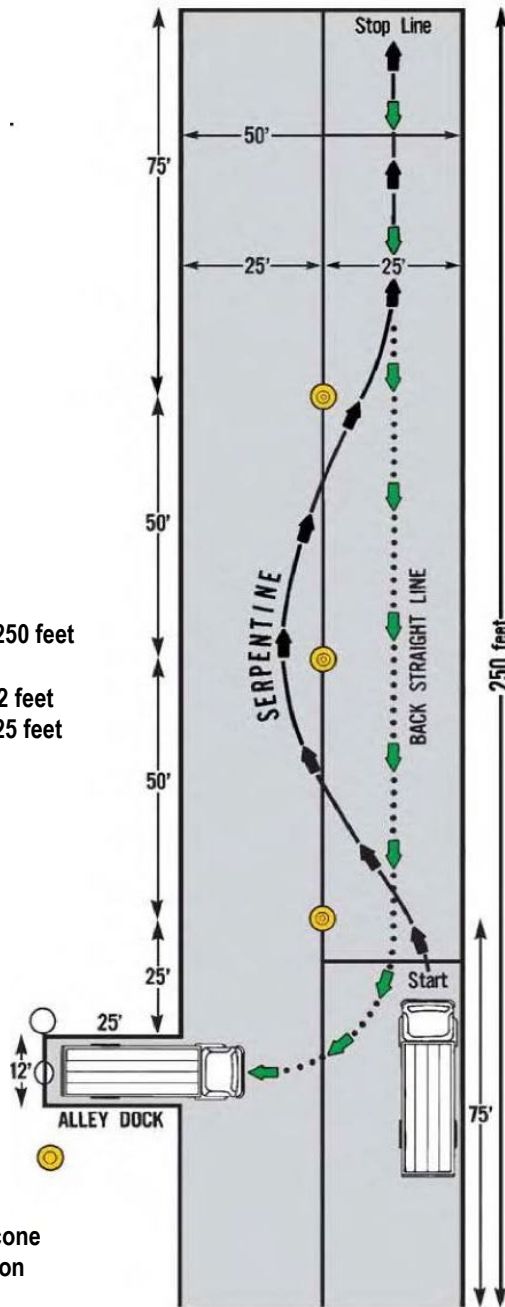

On-Road Driving Test

Stopping and Parking

Stopping or parking on the open highway should be avoided. Stopping on the shoulder area of a high-speed, limited-access highway is particularly dangerous and, except in cases of emergency, illegal. Never stop just over the crest of a hill or on a curve.

When it is necessary to park outside a business or residential district, pull your unit as far to the right, off the traveled portion of the roadway, as is safely possible. You should never leave your truck parked without making sure nothing can move it. State law requires that you move your vehicle clear of the traveled portion of the roadway to allow free passage of other vehicles.

Parking

Never park your vehicle in a position where it obscures another driver's view as he attempts to enter a street or highway from a driveway, truck stop, or other place.

Gears

You must select the proper gear and gear pattern and shift without clashing, forcing, or snapping.

Braking

You must be able to stop your vehicle smoothly without a jerk or rebound at the end of the stop.

Following

You must keep a safe distance behind the vehicle ahead of you in case it should make a sudden stop.

Passing

You must be able to pass legally and safely without interfering with other traffic.

Lane Position

You must keep your vehicle in the proper lane without veering across the centerline or off the right side of pavement.

Intersection

You must maintain the proper safe speed, looking in both directions, and be prepared to stop if traffic on the cross street fails to stop.

Turning

You must give proper signals and be in a proper lane position and at the proper speed when turning.

CONCLUSION

This manual gives you some important information about RV and large non-commercial vehicle safety. A good understanding of RV and large non-commercial vehicle safety and lots of driving practice will help you operate your vehicle with greater confidence and enjoyment.

Remember, you're bigger than they are. Show respect for other vehicles on the road by leaving appropriate space between you and other vehicles.

Be safe and enjoy your travels.